

Lab 17 – Torques/Moments

Name _____

Partner's Name _____

I. Introduction/Theory

Terminology: The word '*torque*' does not typically appear in the index to statics books such as Bedford and Fowler. For these authors, the same idea is expressed as the '*moment of a force*' about a point. Physicists, in turn, never refer to the 'moment of a force', but only to torques. We will attempt to use both terms interchangeably in this discussion.

Background: Torque is the rotational equivalent of force (a force tends to accelerate a body, while a moment of a force tends to make a body rotate.) A force, F , applied at point P is said to exert a torque, τ , or to have a moment, M , with respect to a (reference) point R. For now, we will use the following definition of the magnitude of the moment M of a force applied at point P with respect to point R:

$$\text{magnitude of moment (M) or torque } (\tau) \quad M = \tau = rF\sin(\phi) \quad (1)$$

where \mathbf{r} is a vector drawn from point R (the reference) to point P (where the force \mathbf{F} is applied). The magnitude of \mathbf{r} is r , and ϕ is the angle between \mathbf{r} and \mathbf{F} , traveling clockwise (Figure 1). (Some of you may know that $rF\sin(\phi)$ is the magnitude of $\mathbf{r} \times \mathbf{F}$, the vector cross product of \mathbf{r} and \mathbf{F} .)

Rotational Equilibrium: A body in translational equilibrium has no net forces acting on it: the sum of all forces acting equals zero. A body in rotational equilibrium has no net torque acting on it; the sum of all moments of forces on the body equals zero.

General Idea of the Laboratory Exercises: The main purpose is to acquaint you with the features of torque; the way the torque depends on the distance to the reference point, the angle of application of the force, and the fact that any stationary point R can be selected as a reference. (Once this point is selected, all torques in a given situation must be computed with respect to this point.)

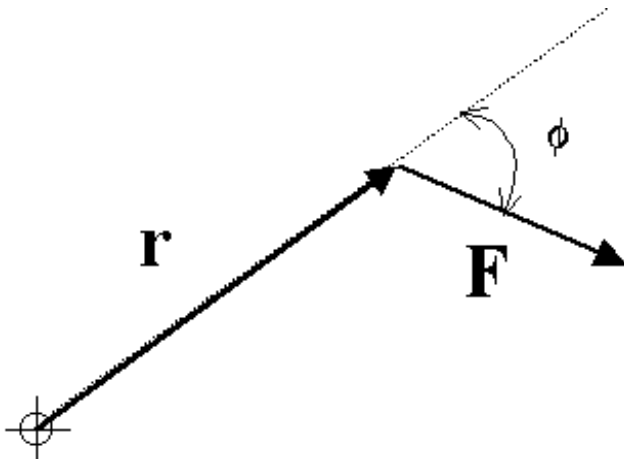

Figure 1

II. Equipment

1000g Spring Scale
 Moments of Force Apparatus (Meter Stick Balance)
 including: Meter stick
 Mass set
 Support Stand
 Lever Knife-edge Clamps (3)

Pan Balance Scale
 Protractor

III. Procedure

Exercise 1

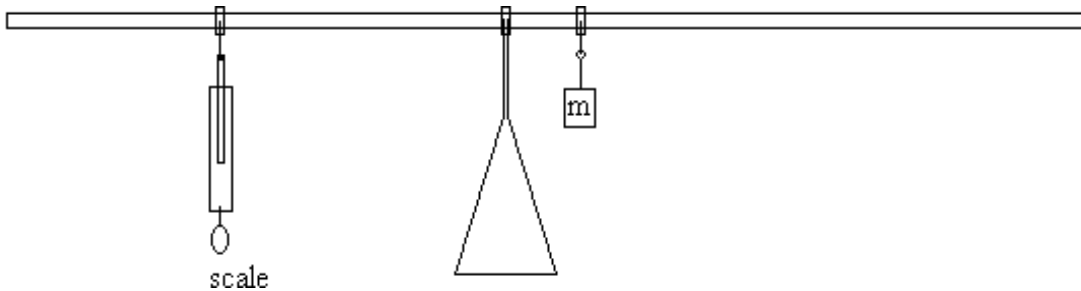

Figure 2: Equipment Setup for Exercise 1

In this exercise you will vary the distance from the pivot point to the spring scale, measuring the force required to keep the bar horizontal at each distance. Set up the 'Meter Stick Balance' pivoted in the middle, so the bar is free to rotate in a vertical plane. Hang a mass of 1.0 kg at a distance of 6 to 9 cm from the pivot point. Attach spring scale on the other end of the meter stick as per Figure 2.

Record the value of the mass and its distance in Table 1. Use the spring scale to horizontally balance the set up at approximately two times, three times, and four times the distance of the 1.0 kg mass. Record the force at the different scale positions to balance the setup in Table 1. Calculate and record torques in Table 1.

	Hanging mass, m	Trial 1 Scale at ~two times	Trial 2 Scale at ~three times	Trial 3 Scale at ~four times
Force (N)				
Dist. (m)				
Torque (N-m)				

Table 1

Exercise 2

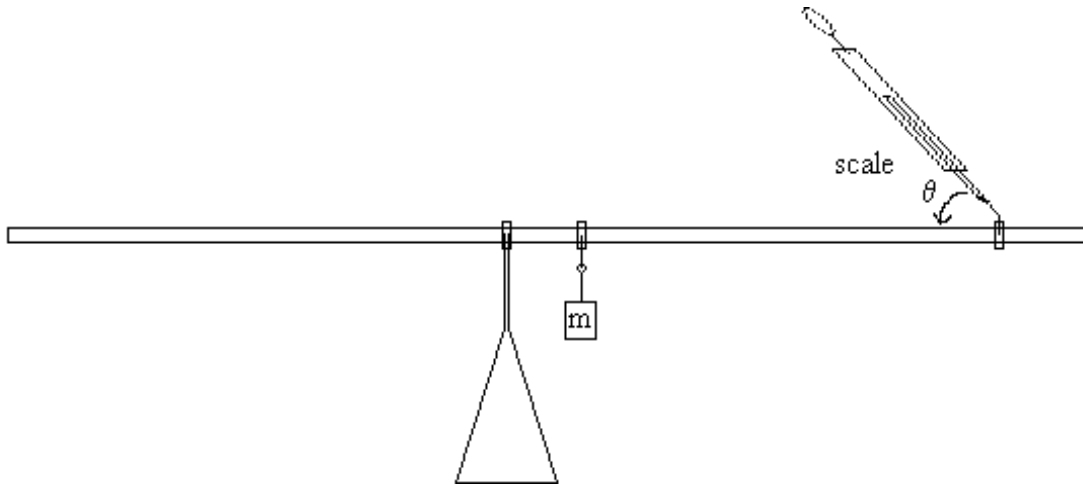

Figure 3: Equipment Setup for Exercise 2

In this exercise you will vary the angle the spring scale makes with the meter stick and measure the force required to keep the bar horizontal for each angle. Using the same mass and distance as in Exercise 1, move the scale (and clamp) to the same side of the meter stick as per Figure 3. Locate the scale as close to the end of the meter stick as is reasonable possible.

Record the value of the mass and its distance in Table 2. Record the forces at angles of approximately 30, 45, 60, and 90 degrees required to level the meter stick. Complete Table 2.

	Hanging mass, m	Scale at $\sim 30^\circ$	Scale at $\sim 45^\circ$	Scale at $\sim 60^\circ$	Scale at $\sim 90^\circ$
Force (N)					
Dist. (m)					
ϕ					
Sin (ϕ)					
Torque (N-m)					

Table 2

Exercise 3

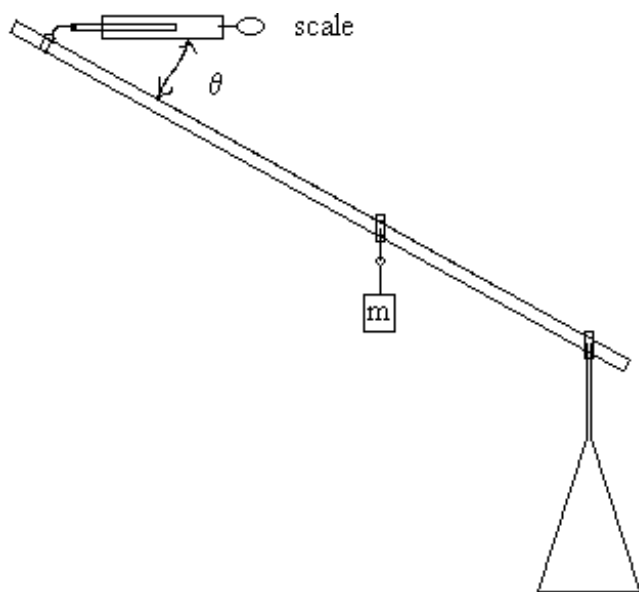

Figure 4: Equipment Setup for Exercise 3

In this exercise you will investigate a case where the measuring bar is not horizontal. Pivot the bar near one end and suspend the 0.5 kg mass near the middle of the meter stick. Attach the spring scale near the other end of the meter stick, see Figure 4.

With the bar at about 45 degrees above the horizontal, pull the spring scale in a horizontal direction toward the pivot point. Move the bar slowly to some convenient angle (don't try for any specific angle like 45 degrees). Notice that the horizontal force on the spring scale for rotational equilibrium varies as the angle of the measuring bar varies. Read the force on the spring scale, and carefully measure horizontal and/or vertical distances which will let you determine the angle of the measuring bar to the horizontal. Do two trials. In the space below record all important information (distances, scale readings, etc.) regarding this procedure.

4. On a clean separate single sheet of paper which will be attached via a staple to this lab, write up the following regarding exercise 3: A physical description of the experiment, compute the torques about the pivot point (taking the CCW torques to be positive and the CW torques to be negative), and investigate the resulting net torque (i.e. does the sum of the moments about R equal zero within your estimated experimental uncertainty?).
- V. Conclusions (include physical concepts and principles investigated in this lab, independent of your experiments success, and summarize without going into the details of the procedure.)